

HSX9000 Series

LOW PHASE NOISE
MULTI-CHANNEL
RF SYNTHESIZERS



The HSX9000 Series offers exceptional phase noise and spectral purity performance as a multi-channel CW signal source. The compact 1U chassis allows for anywhere from 1 to 4 independently tunable channels (frequency / phase offset / amplitude) to optimize channel density within test system racks where real-estate is often crucial. Application specific frequency options can be configured to cover combinations of 10 MHz to **3 GHz, 6 GHz, 12 GHz, 20 GHz, and 40 GHz**. Each broadband channel output provides an accurate dynamic range of up to +20 dBm to -110 dBm. Holzworth's unique multi-loop architecture provides the ultimate in frequency accuracy, channel-to-channel stability and phase coherency.

HSX9000 Series Multi-Channel RF Synthesizers

PHASE COHERENT CHANNELS: 3 GHz–6 GHz–12 GHz–20 GHz–40 GHz



FULLY INDEPENDENT CHANNELS

Each RF output is driven by a separate, internally loaded synthesizer/attenuator module. Up to 4 independently tunable synthesizers can be specified per 1U chassis allowing for the highest integrated channel density available in its class.

PHASE COHERENT CHANNELS

Holzworth HSX9000 Series synthesizers offer the performance benefits of a proprietary multi-loop architecture with a centralized reference distribution subsystem, which maintains a tight phase coherent relationship across all integrated channels.

THE ULTIMATE IN CHANNEL-TO-CHANNEL STABILITY

Different from traditional PLL-based synthesizers, Holzworth's proprietary multi-loop architecture creates precisely synthesized signals that exhibit both instantaneous and long-term stability. Temperature variations between the channels remain the only contribution to drift. The thermally optimized, fan-less chassis was specifically developed for maintaining the lowest possible thermal gradients from channel-to-channel. Channel specific thermal monitoring is available for tracking the relative channel temperature of each loaded synthesizer module.

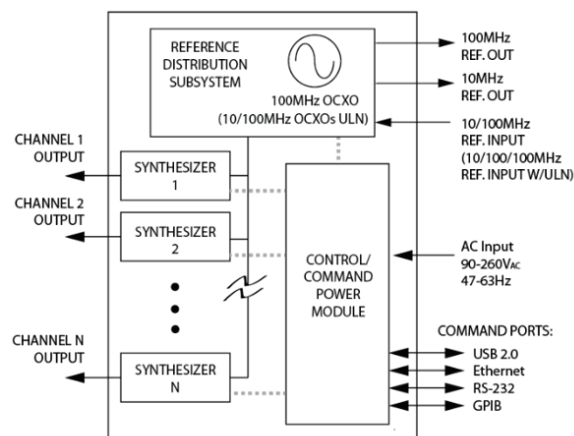

HSX9000 Series Multi-Channel RF Synthesizers

FREQUENCY PERFORMANCE

The specified frequency performance parameters for the HSX9000 Series multi-channel RF synthesizers are fully verified at final performance test and 100% guaranteed for the full warranty period of the product.

PARAMETER	MIN ¹	TYPICAL ²	MAX ¹	COMMENTS
Frequency Range	10 MHz 10 MHz 10 MHz 10 MHz 10 MHz		3 GHz 6 GHz 12 GHz 20 GHz 40 GHz	See page 4 for channel selection options
Switching Speed		5 ms	10 ms	
Frequency Step Size		0.001 Hz		
Phase Offset Resolution		0.1 °		Baseband 750-1500 MHz (N=1) 0.05 ° ±0.05 °
Phase Offset Range		0 to 359.88°, f > 750 MHz		At 100 MHz, 0 to 22.4988°
Internal Time Base Reference (Oscillator Aging Rate)		± 1 ppm/yr		1st year. ±0.5 ppm/yr each subsequent year
Temperature Effects		≤ ± 1 ppm		0 to 55 °C
10 MHz Reference Output				
Amplitude	+2 dBm		+6 dBm	Nominal
Impedance		50 Ω		Nominal
100 MHz Reference Output				
Amplitude	+2 dBm		+6 dBm	Nominal
Impedance		50 Ω		Nominal
External Reference Input (standard)				
Input Frequency		10/100 MHz		
Lock Range		± 4 ppm		
External Amplitude	0 dBm		+10 dBm	
Impedance		50 Ω		Nominal
Waveform				Sine or square
OPT-ULN Ext. Ref. Input (optional)				
Input Frequency Range		10/100/1000 MHz		
Lock Range		+/- 0.5 ppm		
External Amplitude	0 dBm		+10 dBm	
Impedance		50 Ω		Nominal
Waveform				Sine or square

¹ All MIN/ MAX (Minimum/ Maximum) performance parameters are guaranteed and 100% verified during final performance test.

² Typical performance is "by design" and consistent with field performance data.

HSX9000 Series Multi-Channel RF Synthesizers

HSX9000 SERIES CONFIGURATION GUIDE

The HSX9000 Series synthesizer platform is designed to be user/application defined. Follow four easy steps to determine the part number with the required options.

STEP 1: SELECT TOTAL NUMBER OF CHANNELS

Select the base part number, strictly calling out the total number of channels to be loaded into the multi-channel chassis.

No. Channels	1	2	3	4
Part Number	HSX9001A	HSX9002A	HSX9003A	HSX9004A

STEP 2: SELECT CHANNEL FREQUENCY OPTIONS

Select any combination of channel frequency options. Note that the total number of channels specified here must equal the number of channels selected under STEP 1.

Frequency Range	Number of Channels per Frequency Range			
	1x	2x	3x	4x
10 MHz – 3 GHz	OPT-103-X	OPT-203-X	OPT-303-X	OPT-403-X
10 MHz – 6 GHz	OPT-106-X	OPT-206-X	OPT-306-X	OPT-406-X
10 MHz – 12 GHz	OPT-112-X	OPT-212-X	OPT-312-X	OPT-412-X
10 MHz – 20 GHz	OPT-120-X	OPT-220-X	OPT-320-X	OPT-420-X
10 MHz – 40 GHz	OPT-140-X	OPT-240-X	N/A	N/A

STEP 3: SELECT OPTIONS AND ACCESSORIES

TYPE	Part Number	Description
OPTION	OPT-ULN	Ultra-Low Noise: improves close-in phase noise (offsets up to ≤ 100 Hz) and expands external reference options to include 1000 MHz
ACCESSORY	RACK-1U	19" Rack Mount Bracket Kit, 90° rear bracket, 24 in max. depth
ACCESSORY	RACK2-1U	19" Rack Mount Bracket Kit, straight rear bracket, 24 in max. depth
ACCESSORY	RACK-1U-L	19" Rack Mount Bracket Kit, 90° rear bracket, 29 in max. depth
ACCESSORY	RACK2-1U-L	19" Rack Mount Bracket Kit, straight rear bracket, 29 in max. depth
ACCESSORY	CASE-1U	Carrying/storage case

PART NUMBER EXAMPLE

Ordering a 4 channel HSX9000 synthesizer with 1x 10 MHz-6 GHz channel, 2x 10 MHz-12 GHz channels, and 1x 10 MHz-20 GHz channel would result in the following configuration:

Part Number	Description
HSX9004A	4 channel HSX9000 RF Synthesizer
Options	
OPT-106-X	1x 6 GHz Channel
OPT-212-X	2x 12 GHz Channels
OPT-120-X	1x 20 GHz Channel

HSX9000 Series Multi-Channel RF Synthesizers

3 GHz / 6 GHz AMPLITUDE PERFORMANCE

This section contains performance specifications and data for OPT-n03-X (3 GHz) and OPT-n06-X (6 GHz) channels. The specified parameters for the HSX9000 Series RF Synthesizers are fully verified at final performance test and 100% guaranteed for the full warranty period of the product.

PARAMETER	MIN ¹	TYPICAL ²	MAX ¹	COMMENTS	
Output Power (Calibrated) 10 MHz < f ≤ 200 MHz 200 MHz < f ≤ 5.0 GHz 5.0 GHz < f ≤ 6.0 GHz	-110 dBm -110 dBm -110 dBm		+15 dBm +18 dBm +16 dBm	Settable from -115 dBm to +20 dBm	
Maximum Output Power (unleveled) 10 MHz < f ≤ 6.0 GHz		See plot on page 6			
Resolution		0.01 dB			
Connector		50 Ω		SMA (Jack)	
Switching Speed (Amplitude)		5 ms			
Absolute Level Accuracy 10 MHz < f ≤ 6.0 GHz	MAX to +10 dBm +10 to -10 dBm -10 to -60 dBm -60 to -90 dBm <-90 dBm		± 1.0 dB ± 0.7 dB ± 1.0 dB ± 1.3 dB ± 2.0 dB	35 °C to 45 °C case temperature	
SSB Phase Noise (typical) 10 MHz 100 MHz 500 MHz 1 GHz 3 GHz 6 GHz		1Hz ≤ -78 dBc/Hz ≤ -60 dBc/Hz ≤ -47 dBc/Hz ≤ -46 dBc/Hz ≤ -34 dBc/Hz ≤ -23 dBc/Hz	10kHz ≤ -160 dBc/Hz ≤ -156 dBc/Hz ≤ -146 dBc/Hz ≤ -141 dBc/Hz ≤ -131 dBc/Hz ≤ -125 dBc/Hz	1MHz ≤ -161 dBc/Hz ≤ -156 dBc/Hz ≤ -140 dBc/Hz ≤ -134 dBc/Hz ≤ -129 dBc/Hz ≤ -123 dBc/Hz	Output set to +10 dBm
OPT-ULN SSB Phase Noise (typical) 10 MHz 100 MHz 500 MHz 1 GHz 3 GHz 6 GHz		1Hz ≤ -109 dBc/Hz ≤ -87 dBc/Hz ≤ -78 dBc/Hz ≤ -73 dBc/Hz ≤ -61 dBc/Hz ≤ -57 dBc/Hz	10kHz ≤ -160 dBc/Hz ≤ -156 dBc/Hz ≤ -148 dBc/Hz ≤ -145 dBc/Hz ≤ -138 dBc/Hz ≤ -131 dBc/Hz	1MHz ≤ -161 dBc/Hz ≤ -151 dBc/Hz ≤ -140 dBc/Hz ≤ -134 dBc/Hz ≤ -129 dBc/Hz ≤ -122 dBc/Hz	Output set to +10 dBm
Harmonics³ 10 MHz < f ≤ 6.0 GHz		(2ND / 3RD) -35 / -45 dBc	(2ND / 3RD) -20 / -30 dBc	Output set to +10 dBm	
Sub-Harmonics⁴ 10 MHz < f ≤ 1.5 GHz 1.5 GHz < f ≤ 3.0 GHz 3.0 GHz < f ≤ 6.0 GHz			< -70 dBc -70 dBc -60 dBc	< -55 dBc -55 dBc -45 dBc	Output set to +10 dBm
Non-Harmonics / Spurious⁴ 10 MHz < f ≤ 1.5 GHz 1.5 GHz < f ≤ 3.0 GHz 3.0 GHz < f ≤ 6.0 GHz			-88 dBc -83 dBc	-76 dBc -70 dBc -64 dBc	Output set to 10 dBm

¹ All MIN/ MAX (Minimum/ Maximum) performance parameters are guaranteed and 100% verified during final performance test.

² Typical performance is "by design" and consistent with field performance data.

³ RBW: 1.8 kHz, VBW: 1.8 kHz, Span 1 MHz

⁴ RBW: 10 kHz, VBW: 10 kHz, Span 10 MHz

HSX9000 Series Multi-Channel RF Synthesizers

3 GHz / 6 GHz MAXIMUM OUTPUT POWER

The data shown here represents typical unleveled performance.

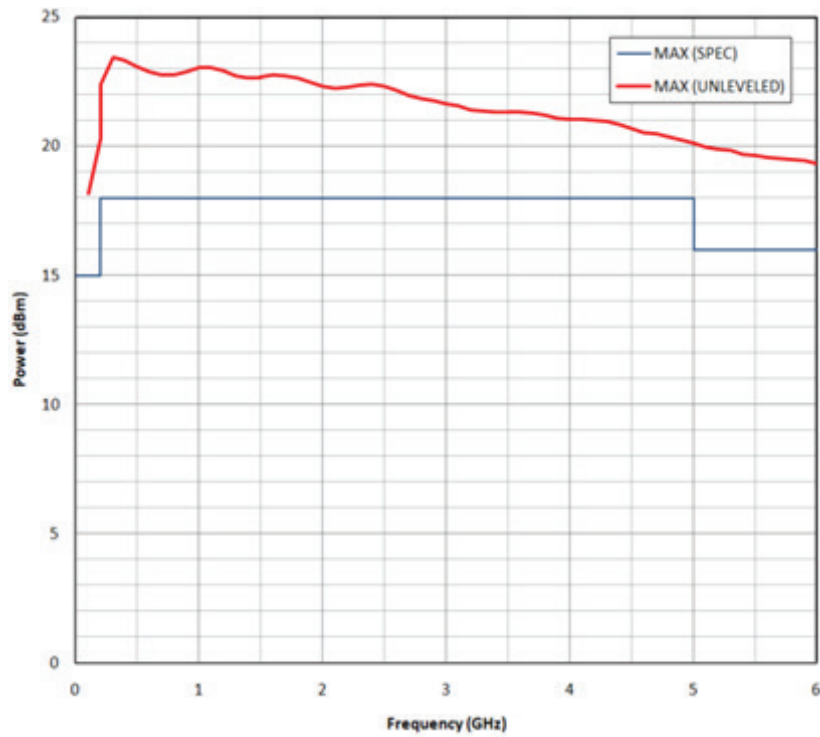

3 GHz / 6 GHz HARMONICS & SUB-HARMONICS

Harmonic and sub-harmonic data taken at +10 dBm carrier power level

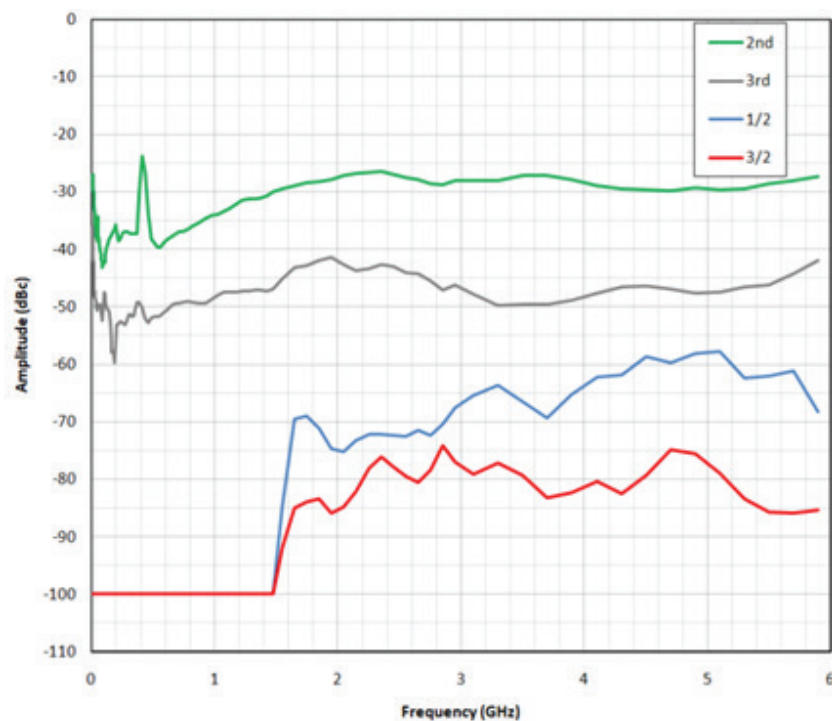

HSX9000 Series Multi-Channel RF Synthesizers

3 GHz / 6 GHz PHASE NOISE PERFORMANCE ($P_{out} = +10 \text{ dBm}$)

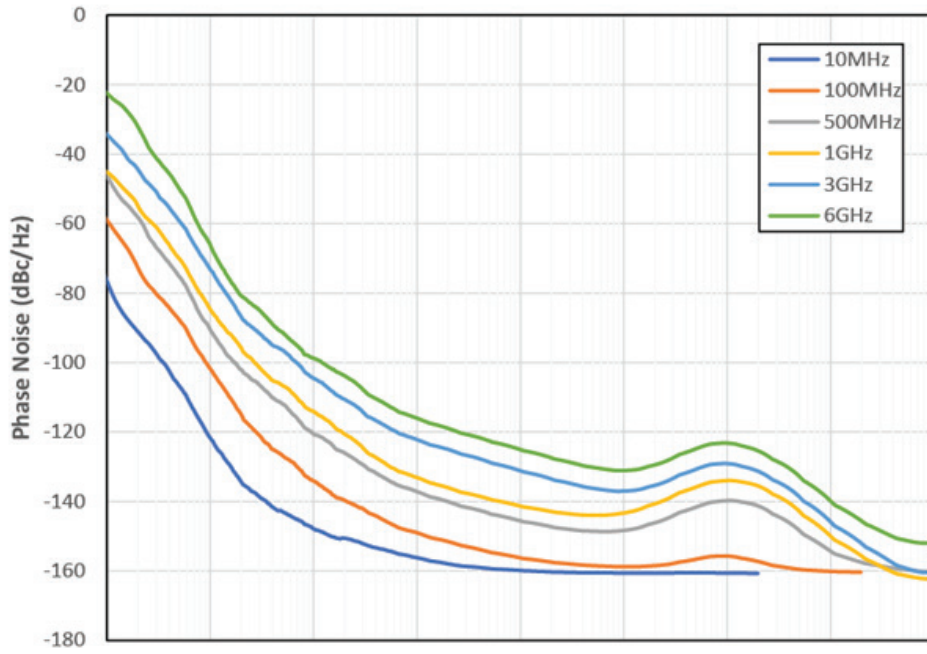

3 GHz / 6 GHz OPT-ULN PHASE NOISE PERFORMANCE ($P_{out} = +10 \text{ dBm}$)

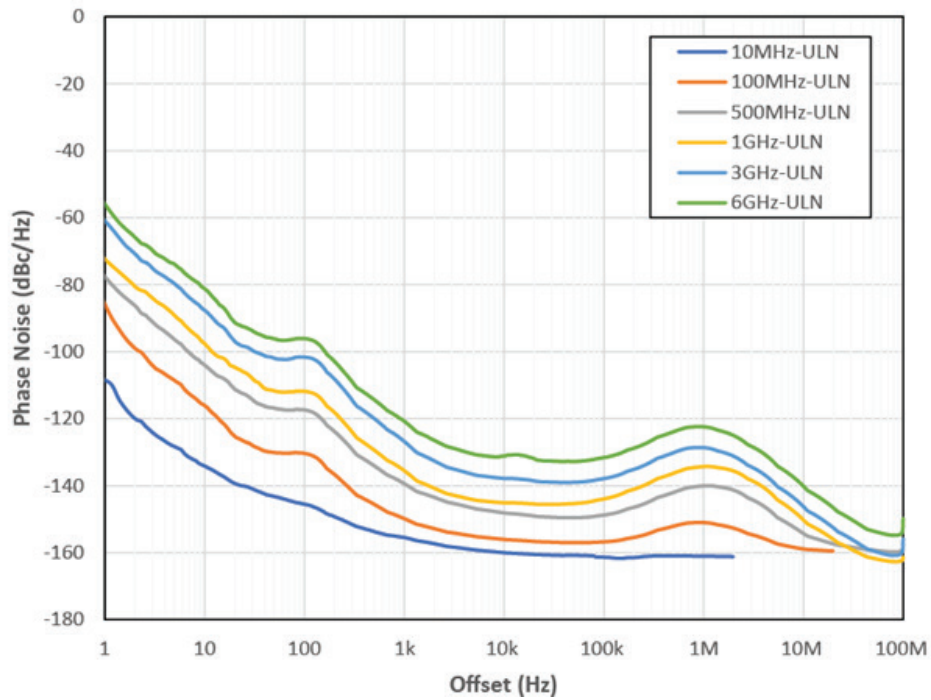

HSX9000 Series Multi-Channel RF Synthesizers

12 GHz / 20 GHz AMPLITUDE PERFORMANCE

This section contains performance specifications and data for OPT-n12-X (12 GHz), and OPT-n20-X (20 GHz) channels. The specified parameters for the HSX9000 Series RF Synthesizers are fully verified at final performance test and 100% guaranteed for the full warranty period of the product.

PARAMETER	MIN ¹	TYPICAL ²	MAX ¹	COMMENTS
Output Power (Calibrated)				
10 MHz < f ≤ 16.0 GHz	-50 dBm		+18 dBm	Settable from -60 dBm to +20 dBm
16.0 GHz < f ≤ 20.0 GHz	-50 dBm		+16 dBm	
Maximum Output Power (unleveled)		See plot on page 9		
10 MHz < f ≤ 20 GHz				
Resolution		0.01 dB		
Connector		50 Ω		OPT-n12-X: SMA (Jack) OPT-n20-X: Super SMA (Jack)
Switching Speed (Amplitude)		5 ms		
Absolute Level Accuracy				
10 MHz < f ≤ 20 GHz				
	MAX to +10 dBm	± 1.4 dB		35 °C to 45 °C case temperature
	+10 to -10 dBm	± 0.7 dB		
	-10 to -50 dBm	± 1.4 dB		
SSB Phase Noise (typical)				
10 MHz	≤ -95 dBc/Hz	≤ -161 dBc/Hz	≤ -163 dBc/Hz	Output set to +10 dBm
100 MHz	≤ -72 dBc/Hz	≤ -157 dBc/Hz	≤ -156 dBc/Hz	
500 MHz	≤ -67 dBc/Hz	≤ -146 dBc/Hz	≤ -139 dBc/Hz	
1 GHz	≤ -60 dBc/Hz	≤ -142 dBc/Hz	≤ -134 dBc/Hz	
3 GHz	≤ -45 dBc/Hz	≤ -132 dBc/Hz	≤ -129 dBc/Hz	
6 GHz	≤ -36 dBc/Hz	≤ -126 dBc/Hz	≤ -123 dBc/Hz	
12 GHz	≤ -34 dBc/Hz	≤ -120 dBc/Hz	≤ -117 dBc/Hz	
20 GHz	≤ -36 dBc/Hz	≤ -115 dBc/Hz	≤ -111 dBc/Hz	
OPT-ULN SSB Phase Noise (typical)				
10 MHz	≤ -105 dBc/Hz	≤ -158 dBc/Hz	≤ -159 dBc/Hz	Output set to +10 dBm
100 MHz	≤ -87 dBc/Hz	≤ -156 dBc/Hz	≤ -151 dBc/Hz	
500 MHz	≤ -73 dBc/Hz	≤ -148 dBc/Hz	≤ -140 dBc/Hz	
1 GHz	≤ -67 dBc/Hz	≤ -145 dBc/Hz	≤ -135 dBc/Hz	
3 GHz	≤ -57 dBc/Hz	≤ -138 dBc/Hz	≤ -130 dBc/Hz	
6 GHz	≤ -56 dBc/Hz	≤ -132 dBc/Hz	≤ -123 dBc/Hz	
12 GHz	≤ -52 dBc/Hz	≤ -126 dBc/Hz	≤ -117 dBc/Hz	
20 GHz	≤ -47 dBc/Hz	≤ -121 dBc/Hz	≤ -113 dBc/Hz	
Harmonics³				
10 MHz < f ≤ 5.0 GHz		(2 ND / 3 RD) -30 / -35 dBc	(2 ND / 3 RD) -20 / -30 dBc	Output set to +10 dBm See plot on page 9 for measured data.
Sub-Harmonics⁴				
10 MHz < f ≤ 1.5 GHz		< -70 dBc	< -55 dBc	Output set to +10 dBm
1.5 GHz < f ≤ 3.0 GHz		-70 dBc	-55 dBc	
3.0 GHz < f ≤ 6.0 GHz		-60 dBc	-45 dBc	
6.0 GHz < f ≤ 12.0 GHz		-70 dBc	-60 dBc	
12.0 GHz < f ≤ 20.0 GHz		-60 dBc	-50 dBc	
Non-Harmonics / Spurious⁴				
10 MHz < f ≤ 750 MHz		< -82 dBc		Output set to +10 dBm
750 MHz < f ≤ 1.5 GHz		-82 dBc	-76 dBc	
1.5 GHz < f ≤ 3.0 GHz		-76 dBc	-70 dBc	
3.0 GHz < f ≤ 6.0 GHz		-70 dBc	-64 dBc	
6.0 GHz < f ≤ 12.0 GHz		-64 dBc	-58 dBc	
12.0 GHz < f ≤ 20.0 GHz		-58 dBc	-52 dBc	

¹ All MIN/ MAX (Minimum/ Maximum) performance parameters are guaranteed and 100% verified during final performance test.

² Typical performance is "by design" and consistent with field performance data.

³ RBW: 1.8 kHz, VBW: 1.8 kHz, Span 1 MHz

⁴ RBW: 10 kHz, VBW: 10 kHz, Span 10 MHz

HSX9000 Series Multi-Channel RF Synthesizers

12 GHz / 20 GHz MAXIMUM OUTPUT POWER

The data shown here represents typical unleveled performance.

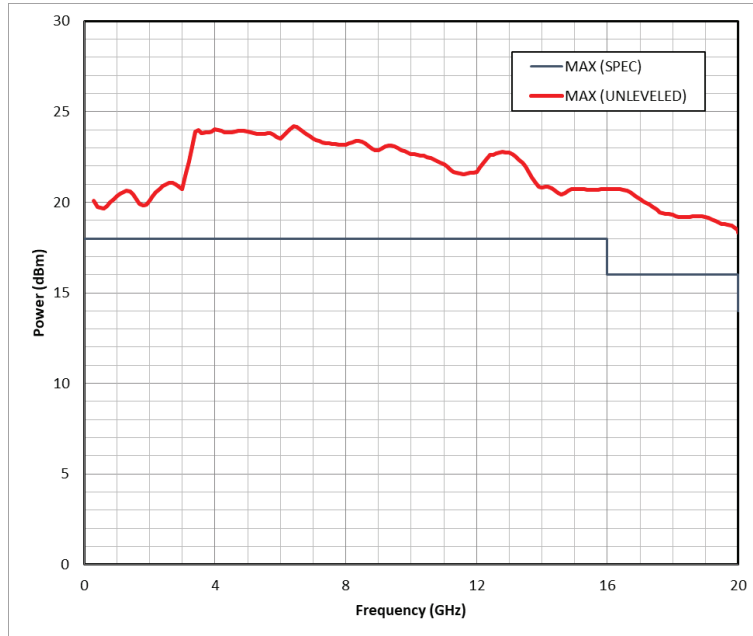

12 GHz / 24 GHz HARMONICS & SUB-HARMONICS

Harmonic and sub-harmonic data taken at +10 dBm carrier power level.

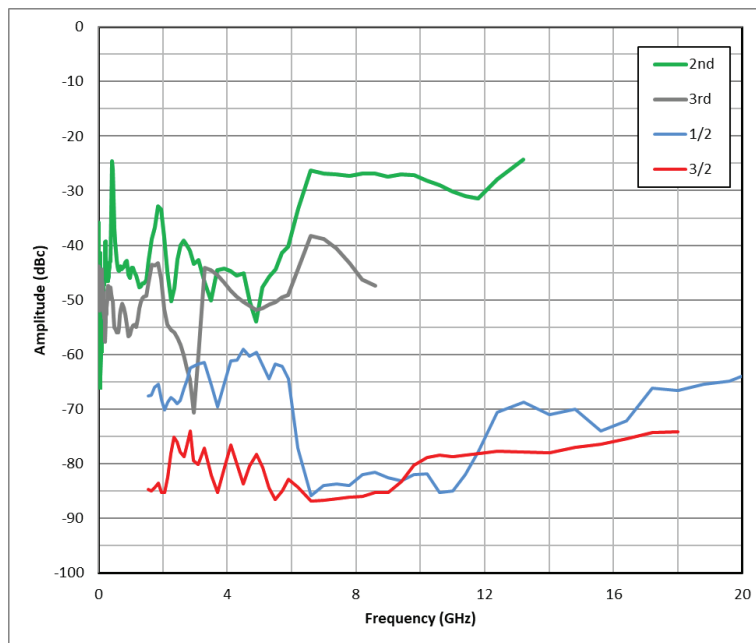

HSX9000 Series Multi-Channel RF Synthesizers

12 GHz / 24 GHz PHASE NOISE PERFORMANCE ($P_{out} = +10 \text{ dBm}$)

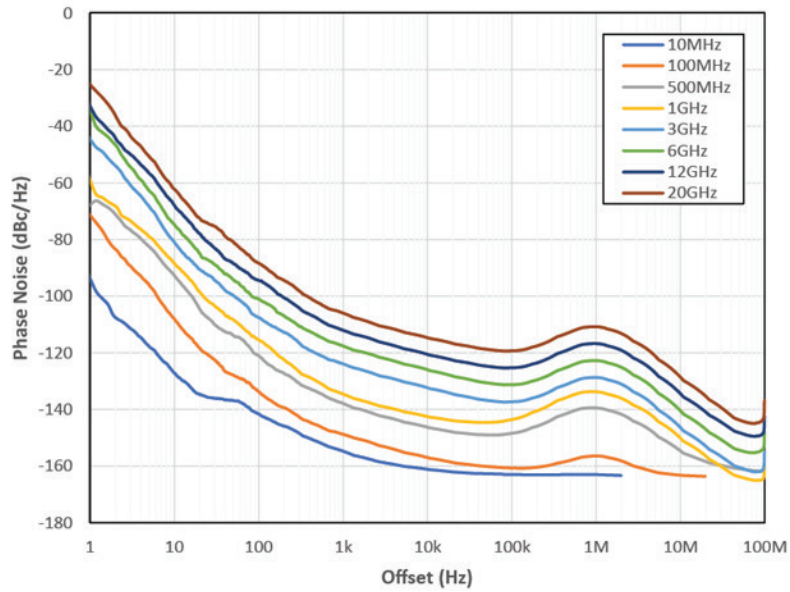

12 GHz / 20 GHz OPT-ULN PHASE NOISE PERFORMANCE ($P_{out} = +10 \text{ dBm}$)

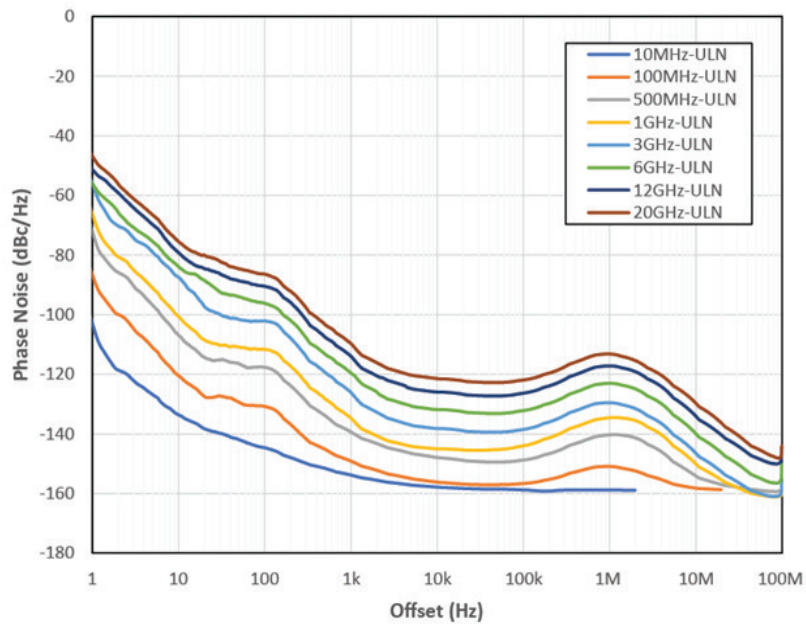

HSX9000 Series Multi-Channel RF Synthesizers

40 GHz AMPLITUDE PERFORMANCE

This section contains performance specifications for channels that operate to 40 GHz. The specified parameters for the HSX9000 Series RF Synthesizers are fully verified at final performance test and 100% guaranteed for the full warranty period of the product.

PARAMETER	MIN ¹	TYPICAL ²	MAX ¹	COMMENTS
Output Power (Calibrated)				
10 MHz < f ≤ 35.0 GHz	0 dBm		+18 dBm	Settable from -5 dBm to +25 dBm
35.0 GHz < f ≤ 40.0 GHz	0 dBm		+13 dBm	
Maximum Output Power (unleveled)		See plot on page 12		
10 MHz < f ≤ 40.0 GHz				
Resolution		0.01 dB		
Connector		50 Ω		2.92 mm (Jack)
Switching Speed (Amplitude)		5 ms		
Absolute Level Accuracy				
10 MHz < f ≤ 35.0 GHz	+18 to 0 dBm	± 0.7 dB		35 °C to 45 °C case temperature
35.0 GHz < f ≤ 40.0 GHz	+12 to 0 dBm	± 1.0 dB		
SSB Phase Noise (typical)	1Hz	10kHz	1MHz	Output set to +10 dBm
10 MHz	≤ -96 dBc/Hz	≤ -158 dBc/Hz	≤ -159 dBc/Hz	
100 MHz	≤ -81 dBc/Hz	≤ -156 dBc/Hz	≤ -155 dBc/Hz	
500 MHz	≤ -61 dBc/Hz	≤ -134 dBc/Hz	≤ -140 dBc/Hz	
1 GHz	≤ -50 dBc/Hz	≤ -142 dBc/Hz	≤ -134 dBc/Hz	
3 GHz	≤ -47 dBc/Hz	≤ -133 dBc/Hz	≤ -128 dBc/Hz	
6 GHz	≤ -40 dBc/Hz	≤ -127 dBc/Hz	≤ -122 dBc/Hz	
12 GHz	≤ -33 dBc/Hz	≤ -121 dBc/Hz	≤ -116 dBc/Hz	
24 GHz	≤ -27 dBc/Hz	≤ -144 dBc/Hz	≤ -110 dBc/Hz	
40 GHz	≤ -21 dBc/Hz	≤ -109 dBc/Hz	≤ -104 dBc/Hz	
OPT-ULN SSB Phase Noise (typical)	1Hz	10kHz	1MHz	Output set to +10 dBm
10 MHz	≤ -104 dBc/Hz	≤ -156 dBc/Hz	≤ -157 dBc/Hz	
100 MHz	≤ -91 dBc/Hz	≤ -155 dBc/Hz	≤ -151 dBc/Hz	
500 MHz	≤ -79 dBc/Hz	≤ -147 dBc/Hz	≤ -140 dBc/Hz	
1 GHz	≤ -70 dBc/Hz	≤ -144 dBc/Hz	≤ -134 dBc/Hz	
3 GHz	≤ -61 dBc/Hz	≤ -138 dBc/Hz	≤ -128 dBc/Hz	
6 GHz	≤ -58 dBc/Hz	≤ -132 dBc/Hz	≤ -123 dBc/Hz	
12 GHz	≤ -49 dBc/Hz	≤ -126 dBc/Hz	≤ -117 dBc/Hz	
24 GHz	≤ -47 dBc/Hz	≤ -120 dBc/Hz	≤ -113 dBc/Hz	
40 GHz	≤ -45 dBc/Hz	≤ -115 dBc/Hz	≤ -107 dBc/Hz	
Harmonics³		(2ND / 3RD)	(2ND / 3RD)	Output set to +10 dBm See plot on page 12 for measured data.
10 MHz < f ≤ 25.0 GHz		-30 / -35 dBc	-20 / -30 dBc	
> 25.0 GHz		-30 / -35 dBc		
Sub-Harmonics³				Output set to +10 dBm See plot on page 12 for measured data.
10 MHz < f ≤ 1.5 GHz		< -70 dBc	< -55 dBc	
1.5 GHz < f ≤ 3.0 GHz		-70 dBc	-55 Bc	
3.0 GHz < f ≤ 6.0 GHz		-60 dBc	-45 dBc	
6.0 GHz < f ≤ 12.0 GHz		-70 dBc	-60 dBc	
12.0 GHz < f ≤ 24.0 GHz		-60 dBc	-50 dBc	
24.0 GHz < f ≤ 40.0 GHz		-60 dBc	-60 dBc	
Non-Harmonics / Spurious⁴				Output set to +10 dBm
10 MHz < f ≤ 750 MHz		< -82 dBc		
750 MHz < f ≤ 1.5 GHz		-82 dBc	-76 dBc	
1.5 GHz < f ≤ 2.0 GHz		-76 dBc	-70 dBc	
2.0 GHz < f ≤ 6.0 GHz		-70 dBc	-64 dBc	
6.0 GHz < f ≤ 12.0 GHz		-64 dBc	-58 dBc	
12.0 GHz < f ≤ 24.0 GHz		-58 dBc	-52 dBc	
24.0 GHz < f ≤ 40.0 GHz		-52 dBc	-46 dBc	

¹ All MIN/ MAX (Minimum/ Maximum) performance parameters are guaranteed and 100% verified during final performance test.

² Typical performance is "by design" and consistent with field performance data.

³ RBW: 1.8 kHz, VBW: 1.8 kHz, Span 1 MHz

⁴ RBW: 10 kHz, VBW: 10 kHz, Span 10 MHz

HSX9000 Series Multi-Channel RF Synthesizers

40 GHz MAXIMUM OUTPUT POWER

The data shown here represents typical unleveled performance.

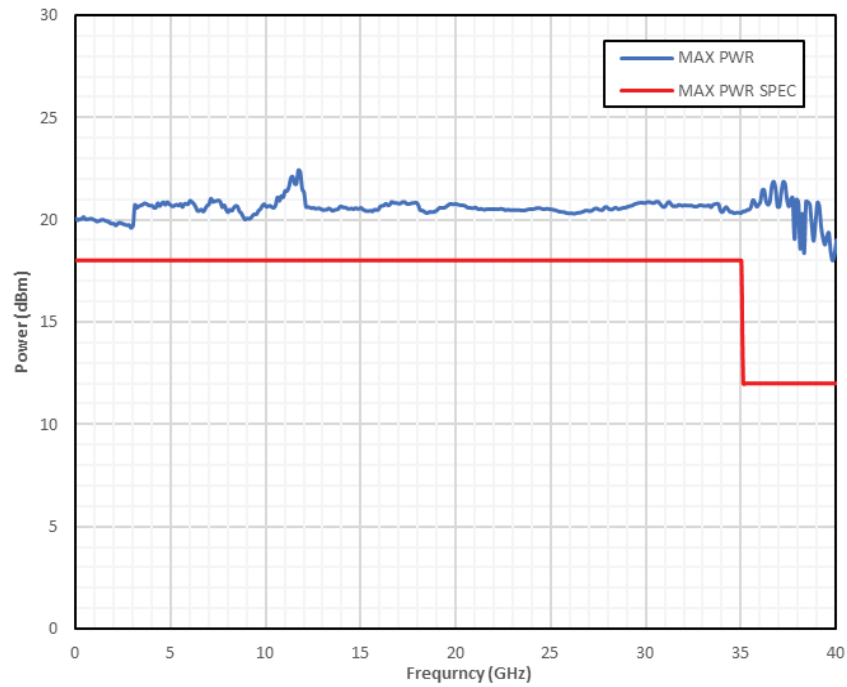

40 GHz HARMONICS & SUB-HARMONICS

Harmonic and sub-harmonic data taken at +10 dBm carrier power level.

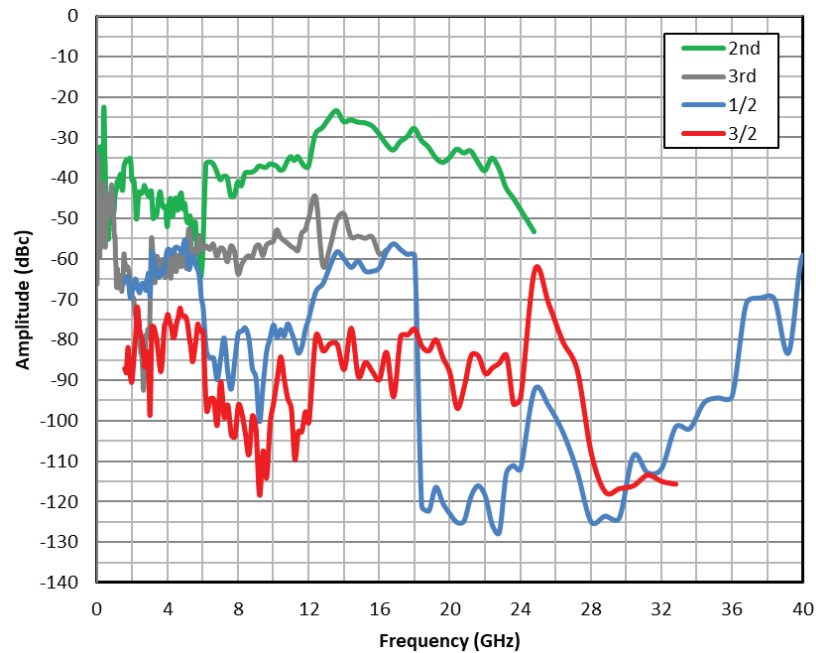

HSX9000 Series Multi-Channel RF Synthesizers

40 GHz PHASE NOISE PERFORMANCE ($P_{out} = +10 \text{ dBm}$)

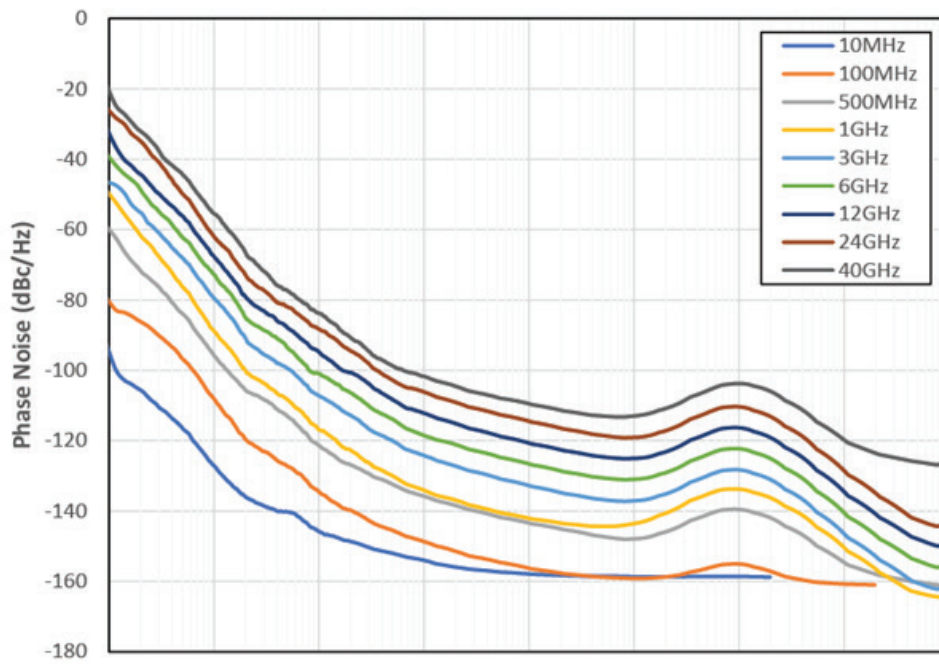

40 GHz OPT-ULN PHASE NOISE PERFORMANCE ($P_{out} = +10 \text{ dBm}$)

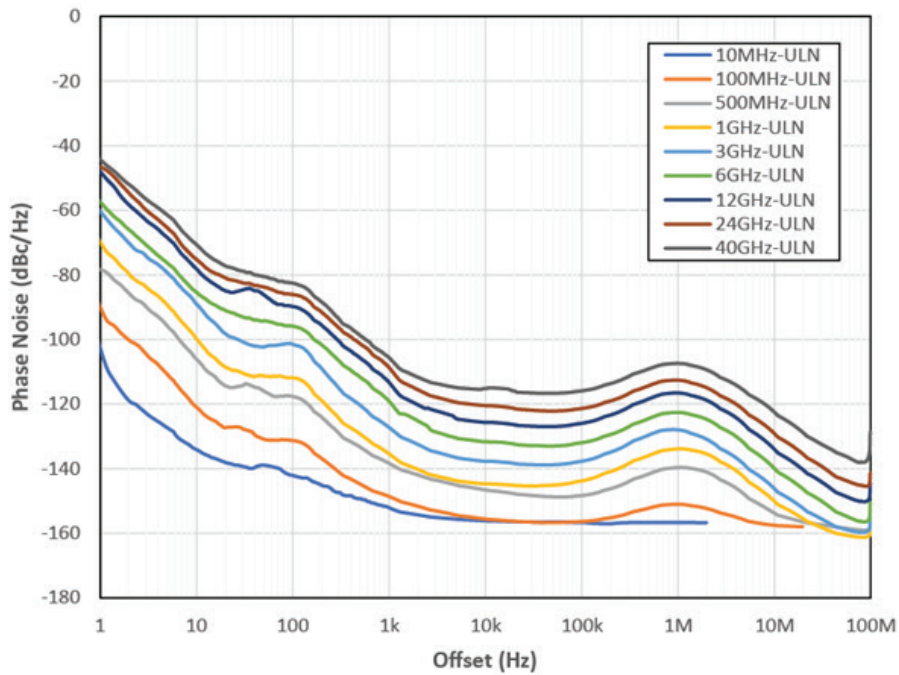

HSX9000 Series Multi-Channel RF Synthesizers

STANDARD VS OPT-ULN REFERENCE PHASE NOISE COMPARISON ($P_{out} = +10 \text{ dBm}$)

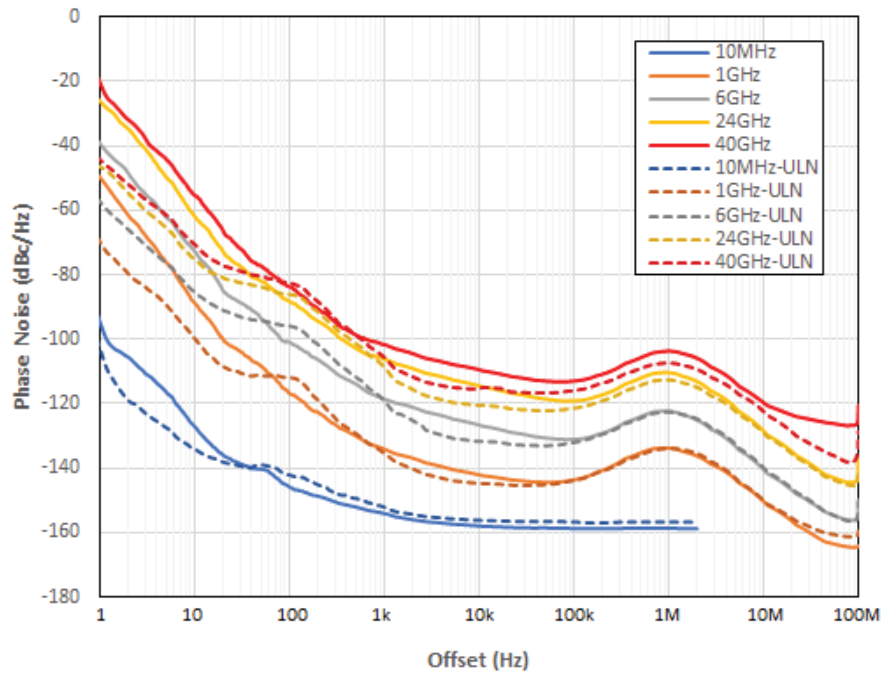

HSX9000 Series RF Synthesizers

ENVIRONMENTAL SPECIFICATIONS

THIS INSTRUMENT IS DESIGNED FOR INDOOR USE ONLY.

Environmental specifications are based on component margins, thermal verification testing and current draw tests. Production unit performance is not verified over temperature.

PARAMETER	MIN ¹	TYPICAL ²	MAX ¹	COMMENTS
Operating Temperature	0 °C		+60 °C	Internal temperature
Temperature Monitor Range	-40 °C		+85 °C	Absolute, channel dedicated sensor
AC Power Supply				
Rated Voltage	100 VAC		240 VAC	
Voltage Range	90 VAC		264 VAC	
Rated Frequency	50 Hz		60 Hz	
Frequency Range	47Hz		63 Hz	
AC Power Consumption				Approximate values. May vary with loading and temperature.
Chassis		14-24 W		Chassis includes reference and communication module.
3 or 6 GHz Channel (each)		17 W		HSX9003 (3 channel) Example:
12 GHz Channel (each)		24 W		14 W + (17 W * 3) = 65 W Total
20 GHz Channel (each)		24 W		
40 GHz Channel (each)		49 W		
Warm-Up Time		10 min		20 °C (ambient temp. dependent)

¹ All MIN/ MAX (Minimum/ Maximum) performance parameters are guaranteed and 100% verified during final performance test.

² Typical performance is "by design" and consistent with field performance data.

DESCRIPTION	Recommended Environmental Conditions
Operating Environment	
Humidity	Relative humidity 15% to 95%, <29 °C (non-condensing)
Altitude	0 to 3,048 m (0 to 10,000 feet)
Vibration	0.21 g RMS maximum, 5 Hz to 500 Hz
Storage (Non-Operating)	
Temperature	-10 °C to + 60 °C
Humidity	Relative humidity 0% to 90%, <40 °C (non-condensing)
Altitude	0 to 15,240 m (0 to 50,000 feet)
Vibration	0.5 g RMS maximum, 5Hz to 500Hz

REGULATORY COMPLIANCE

CE compliance with the following European Union directives
 Low Voltage Directive EU 2014/35
 Electromagnetic Compatibility Directive (EMC) EU 2014/30
 RoHS Directive EU 2015/863, WEEE Directive EU 2012/19

HSX9000 Series Multi-Channel RF Synthesizers

MECHANICAL CONFIGURATION

The HSX9000 Series comes in a 1U high, rack mountable chassis. The example shown is of a 4 channel unit (front panel configuration may vary). A universal rack mount bracket kit is an available accessory (Part No.: RACK-1U , RACK-1U-L, RACK2-1U, RACK2-1U-L). Mechanical dimensions are listed in inches (and millimeters).

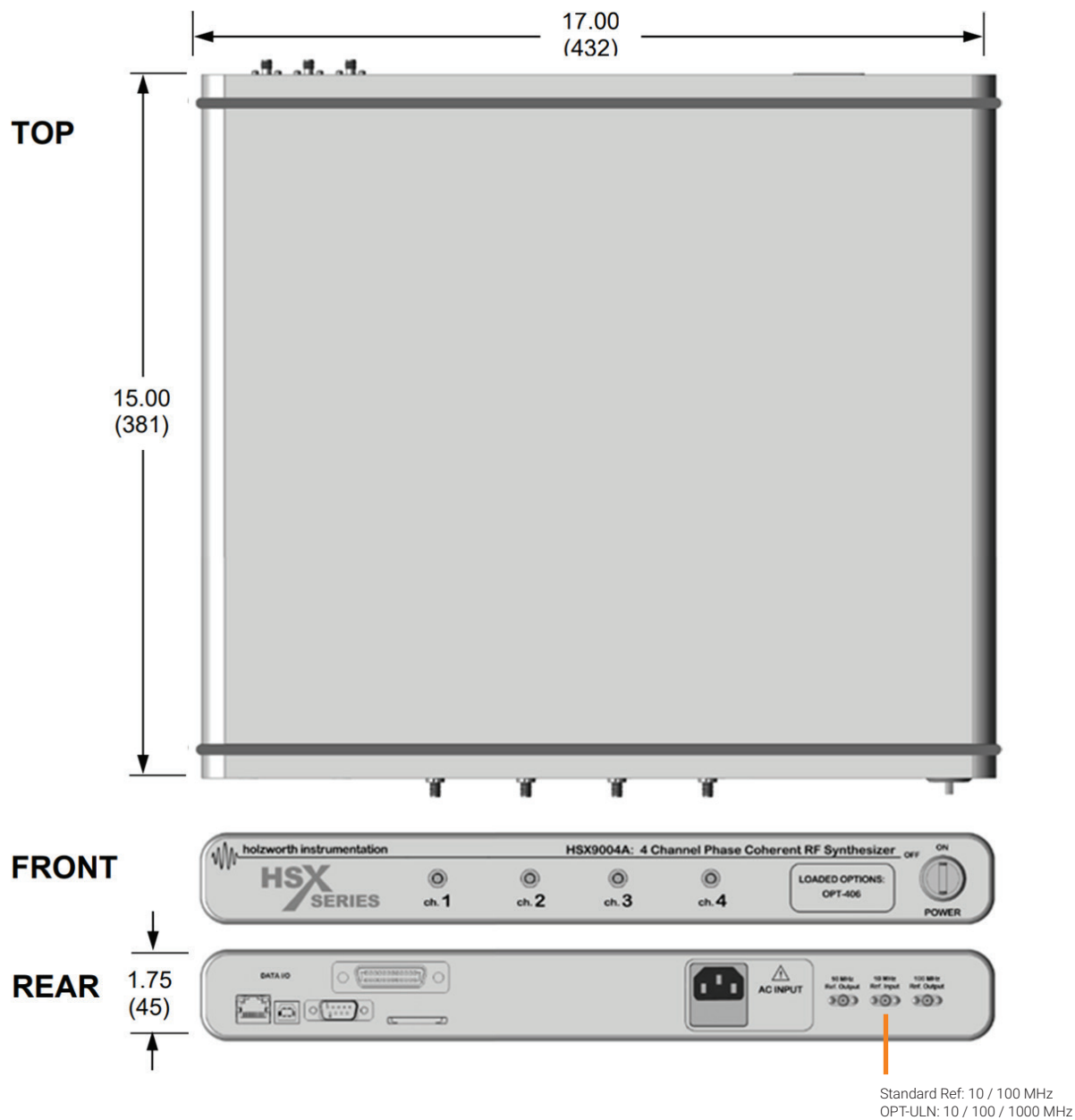

HSX9000 Series Multi-Channel RF Synthesizers

CONNECTORS and PHYSICAL SPECIFICATIONS

FULLY INDEPENDENT CHANNELS

DESCRIPTION	Configuration
RF Output(s) Connector Type	SMA-J, 50 Ω: OPT-n03-X, OPT-n06-X, OPT-n12-X (n = number of channels = number of connectors) Super SMA-J, 50 Ω: OPT-n20-X (n = number of channels = number of connectors) 2.92mm-J, 50 Ω: OPT-n40-X (n = number of channels = number of connectors)

REAR PANEL

DESCRIPTION	Configuration
Reference Output Port Connector Type Output Frequency Output Level Output Waveform	SMA, 50 Ω 10 MHz ±10 Hz and 100 MHz ±100 Hz +2 dBm to +6 dBm Sinusoid
Reference Input Port Connector Type Input Frequency Input Frequency (OPT-ULN) Input Level	SMA, 50 Ω 10/100 MHz 10/100/1000 MHz 0 dBm to +10 dBm (sinusoid or square)
AC Power Input Connector Type AC Input Rating	IEC 320-C13 100-240 VAC, 47-63 Hz. Specify country at time of order for proper power cord.
Data I/O Interface Connectivity	USB B-Type (virtual COM port), Ethernet, RS-232, GPIB

PHYSICAL

Dimensions (L x W x H)	1U high, 19" rack mount: 15 in x 17 in x 1.75 in (381 mm x 431.8 mm x 44.5 mm)
Weight	25 lbs. (11.34 kilograms) MAXIMUM

HSX9000 Series Multi-Channel RF Synthesizers

INCLUDED HARDWARE AND CERTIFICATIONS

Each product delivery includes following hardware and certifications.

DESCRIPTION

HSX9000 SERIES SYNTHESIZER

AC Power Cord (7 ft/2.1 m)¹

Ethernet Cable (10 ft/3 m)

USB Cable (6 ft/1.8 m)

CALIBRATION CERTIFICATION

¹ Specify final country of destination for shipment with proper power cord

HSX9000 Series Multi-Channel RF Synthesizers

INTERFACE - GUI

The HSX9000 Series hardware utilizes a virtual front panel as the control interface. Each unit comes with an open license to operate the application on any standard PC, including those equipped with touch screen monitors. The C++ based application GUI compliments the driver free instrument by being extremely reliable. The units can also be directly accessed via any data I/O interface for control via MATLAB™, LabVIEW™, C++ code, Python, VB code, etc.

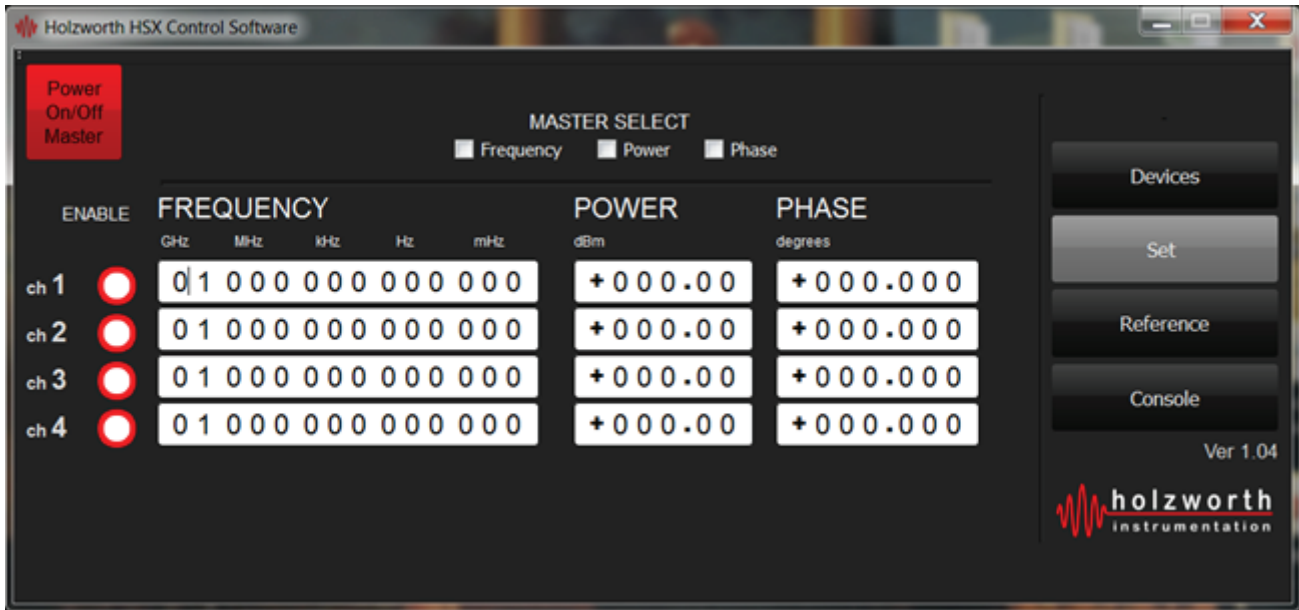

HSX9000 Series Multi-Channel RF Synthesizers

WARRANTY

All Holzworth HSX9000 Series synthesizer products come with a standard 3 year 100% product warranty covering manufacturing defects. All product repairs and maintenance must be performed by Holzworth Instrumentation. Holzworth reserves the right to invalidate the warranty for any products that have been tampered with or used improperly. Refer to Holzworth Terms & Conditions of Sales for more details.

Holzworth products are proudly designed and assembled in the USA.

CONTACT INFORMATION

Contact Holzworth directly for a product quotation, a product demonstration, or for technical inquiries.

Holzworth Instrumentation Sales Support

Phone: +1.303.325.3473

Holzworth Instrumentation Technical Support

Phone: +1.303.325.3473

Email: support@holzworth.com



Wireless Telecom Group Inc.

25 Eastmans Rd
Parsippany, NJ
United States
Tel: +1 973 386 9696
Fax: +1 973 386 9191
www.holzworth.com

© Copyright 2022
All rights reserved.

H/HSX Series/0722/EN
Note: Specifications, terms and conditions are subject to change without prior notice.